



FT FLUIDOTEHNIC

ELECTROHYDRAULIC THRUSTERS

CATALOG OF DEVICES

FT www.fluidotehnic.com



Fluidotehnic d.o.o.
Serbia

36210 Vrnjacka Banja
Rudjinci 175/A

Tel: +381-(0)36-631-710
+381-(0)36-631-711

Fax: +381-(0)36-631-712

www.fluidotehnic.com
office@fluidotehnic.com



SERIES "ESM"

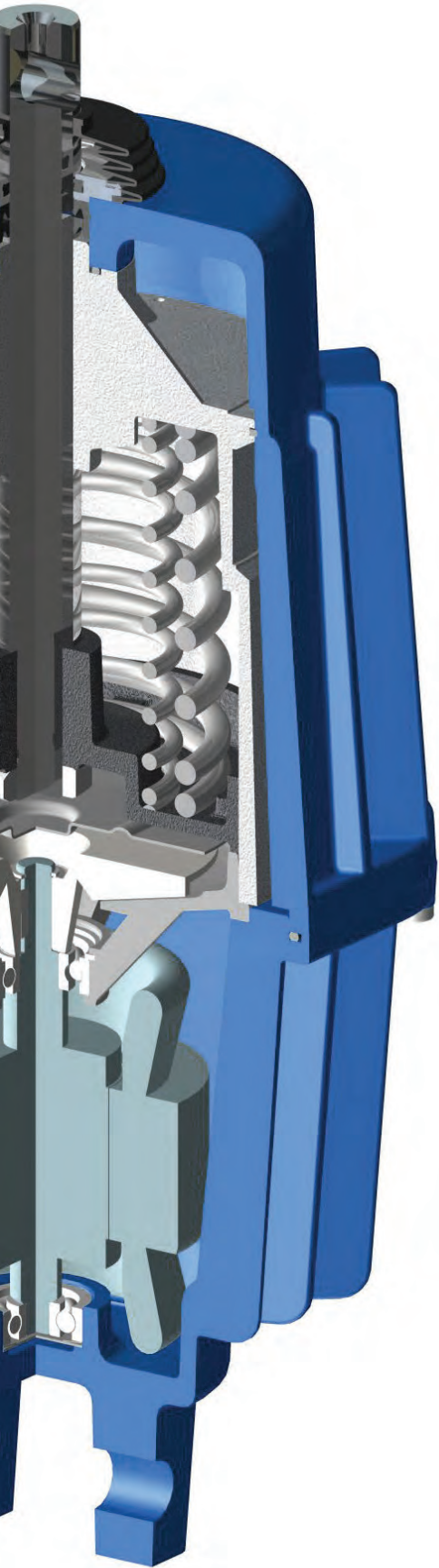

Easy installation and deinstallation

Short actuating times

High operational safety

Ability to work from -45°C to $+70^{\circ}\text{C}$

Standard version 2000c/h or ED100% (S1)

 Different voltages and frequencies of electric power

 Standard mechanical protection IP66

 Resistance to heavy duty

 External controllers of device

 Internal controllers of device



TECHNICAL DESCRIPTION OF THE DEVICE

Housing of the motor **(1)** is constructed with eyelet connection and can be fixed on fundament by a bolt. There is also oil drain plug on the housing. Driving motor stator **(3)** (squirrel cage asynchronous motor) is fitted in the housing. Connecting box for electrical supply **(11)** is fixed on the housing hermetically separated from the inside of the housing. The rotor **(2)** is fixed in the housing by its downside, and upside fitted in the turbine bearing **(4)**. The turbine wheel **(5)** is mounted on the rotor shaft. The guide cylinder **(8)** with piston **(12)** and rod **(14)** is located upper the turbine.

In the guide cylinder is also screw **(13)** for adjusting speed of the rod. On the upper side the guide cylinder is covered by upper housing **(10)**, which with the motor housing forms a functional entirety.

The transformer oil fills interior of the device. The electric motor drives the turbine, which produce oil pressure downside of the piston. The piston and the rod are forced to move upward. The oil from upside of the piston returns through the holes to the turbine inlet. Hydraulic force is completely independent of the piston position, it depends only of the speed of turbine (current frequency), turbine size, and of the piston diameter. When lifting, motion is uniformly in the range of nominal force, independent of the load.

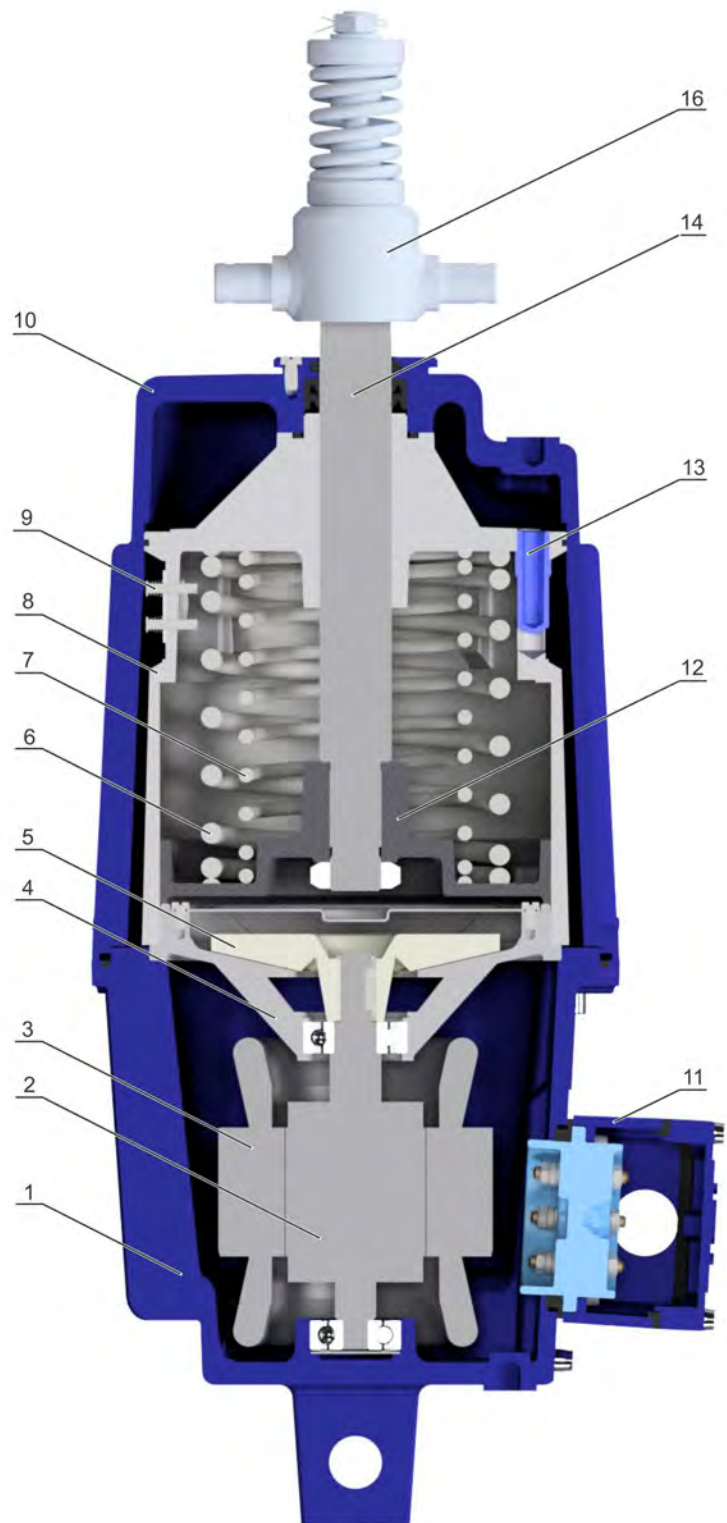

Pushing force gradually increase during 0.1 – 0.15 s, which provide very soft start of the rod. Electric motor has excellent cooling since transformer oil transfers heat to device housing and over the fins is transferred to the environment.

This device construction provides a constant output force, regardless of the position of the piston rod and the possibility of continuous operation without overloading. Switching off the electric motor, outside load caused the backward movement. Oil under the piston is suppressed back through the circuit of the turbine and through the corresponding holes exceeds into the zone above the piston. Oil level in device should be on the down blade of the filling port on upper housing (10) (device is in the vertical position). In the case of recharge, previously removed regulating screw (13).

Any position of the rod could be chosen for the output position. This is very important for brake releasing application, because thus compensate for brake linings wear. It is recommended that the brake should be adjusted (when it is completely closed) for 1/3 stroke of the rod.

Constructive, all sizes based on the same principle, except ESM-320, which, due required pushing force, have twostage turbine circuit. Thus was obtained the required pushing force from the device which has the same external dimensions like ESM-250.

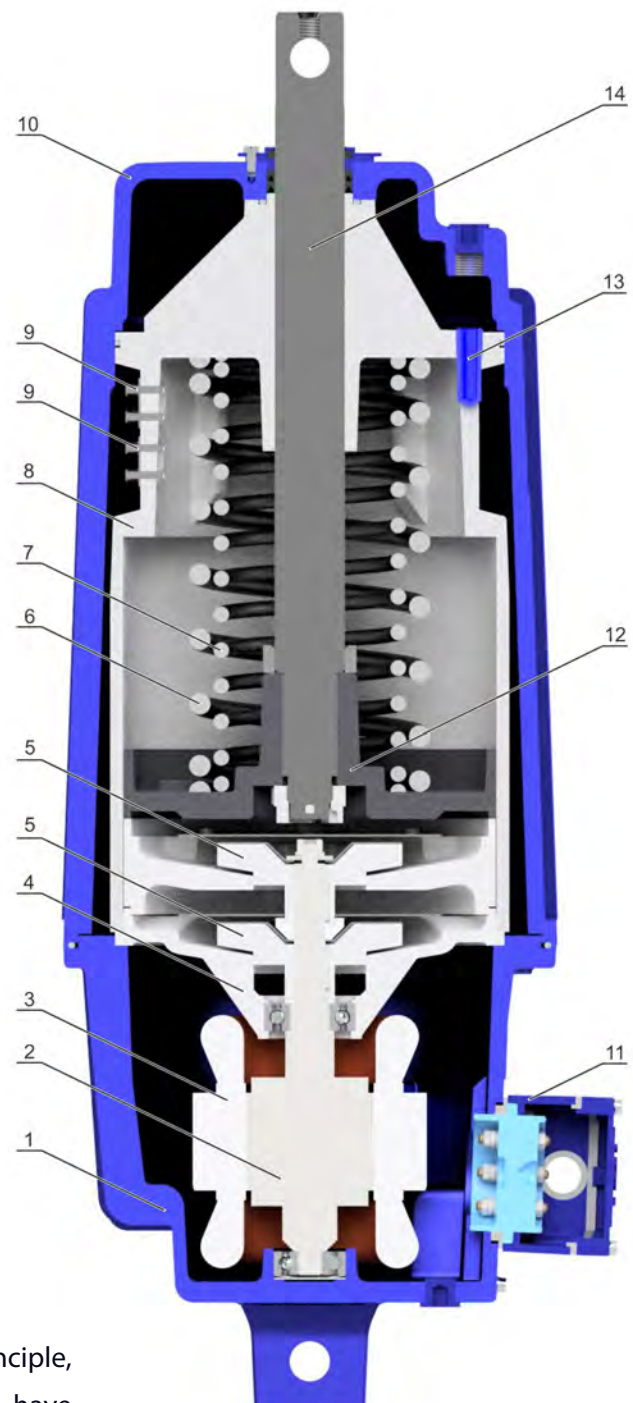

According to the customer request, several versions also available:

Device with return springs C (6,7)

One or two springs are mounted upper the piston. The piston forced back to the start position by the spring, after the motor switching off. There are three versions of the device, depends of the spring force: internal, external and both of them. It should be considered that the spring force reduces the nominal output force. The nominal return spring force is given according to the piston position on the 1/3 stroke. In full extract position of the rod, real return force exceeds nominal value for approximately 20%, in full retract position, pushing force is reduced for 10%.

Device with shock absorber R (16)

The shock absorber, fixed on the rod, prevents starting and stopping shocks and enables swiveling of the brake mechanism around the rod axe and around the perpendicular axe. This provides gradual increasing of the braking force up to a maximum.

Device with speed control valve (9)

The speed control valve is build on the cylinder holes and, depends of the type, prevent the one of the flow directions. There are few types of speed controls valves:

Check valve for the lifting speed control - H.

In case of the piston movement to the upper position, check valve is closed so the flow is enabling only through the port beside the adjustment screw (13). Then the speed is determined by the screw position. When the piston moves down, the check valve is opened and speed is maximal. Turning the adjustment screw in clockwise direction produces lower, counter clockwise higher speed. Before the adjusting it is necessary to remove the socket screw for filling.



Check valve for the lowering speed control - S.

The function of the valve is opposite as already described, the downward speed is determined by the screw position.

Throttle valve for the speed control in the both directions - D.

The flow is restricted in the both of the directions and it always depends of the adjustment screw position.

It should be considered that these valves reduce speed of the device. If the maximum speed is necessary, the valves should not be used!

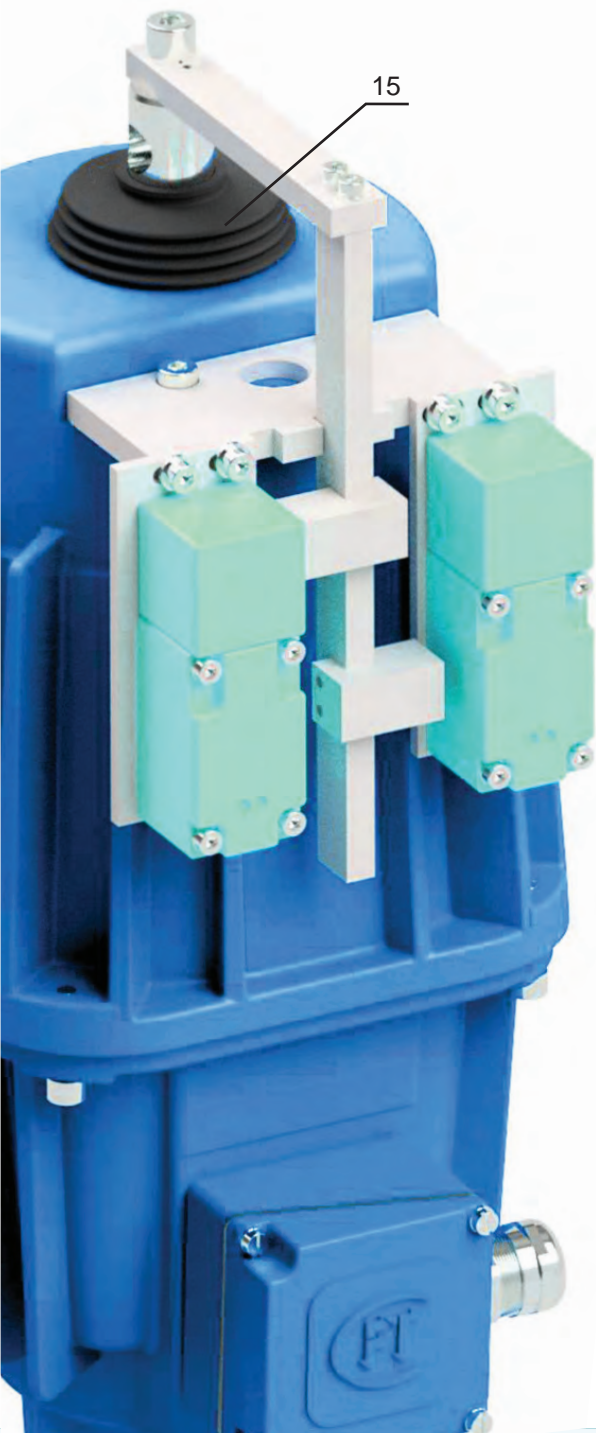

Device with cover protection (15)

The cover protects the rod and seal set from dust penetration. It allows long life of the device in heavy operating conditions (surface minings and cement industry).

Working signalisation of the device

- Device with external mechanical switch **Im** and **Im1** (brake open, linings worn)
- Device with inside mechanical switch **MP** (brake open)
- Device with external inductive switch **In** and **In1** (brake open, linings worn)
- Device with inside magnet-inductive switch **Lk2** and **Lk4** (brake open, linings worn)

We meet the special customer requests for voltage and frequency. For extremely hard operation conditions, such as permanent operation under tropic temperature, or for the periodical operation under extremely low temperature, we used special seals, electric motors and adequate synthetically oils. To choice the best solution, we recommend to contact our experts.

VARIANTS OF INSTALLATION

The device is possible to use in vertical, horizontal (lifting rod in horizontal position $\pm 30^\circ$) or inverted position. In the vertical position, installation and operation are easiest. In the horizontal and inverted positions, the device may be installed so that the terminal box will be located at the side, provided the symbol „ II “ was added after the type designation in the order. If in the horizontal service position space considerations require to mount the terminal box either on top or on the bottom, a modification of the device is required and has to be carried out by a specialist. When ordering this version, the symbol „ I “ must be added after the type designation. If the devices are to be used in an inverted position (lifting rod vertically downwards $\pm 60^\circ$), consultation with manufacturer is necessary.



VARIANT "II"

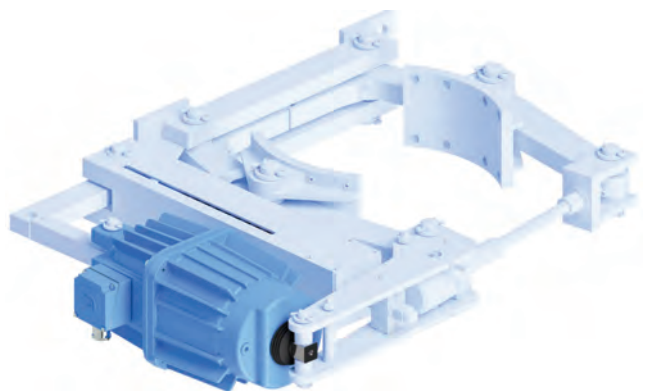
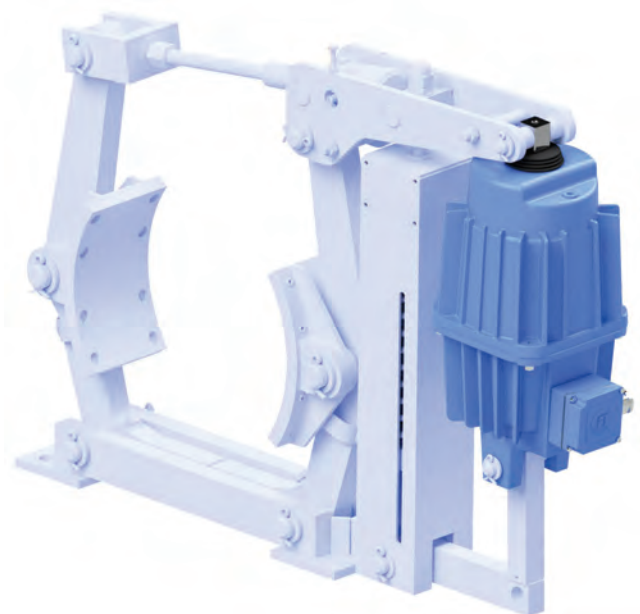

EXAMPLES FOR VARIANT "II"



EXAMPLE FOR VARIANT "I"

The point is that, when installing the device in a horizontal position, the plane in which the piston rod **(14)** and the control bolt **(13)** are located are horizontal. In this way, the device will work properly and have adequate technical characteristics.



VARIANT "I"

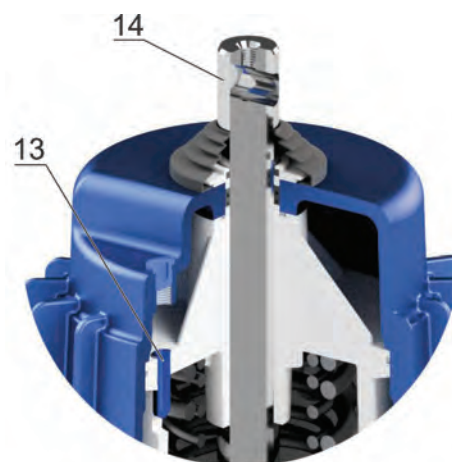

**External mechanical switch
“Im” and “Im1”**



**External inductive switch
“In” and “In1”**



Microswitch is build on the outside of cylinder. It is activate when the piston is in the top position. In a magnetic inductive switch, switches are also built on the outside of the cylinder and activates them a permanent magnet built in the piston. The advantage of this solution is that the switches are fully protected from external influences and in this way are very reliable in the work. Linkage is done in connecting box.

**Internal mechanical switch
"MP"**

**Internal magnet-inductive switch
"Lk2" and "Lk4"**

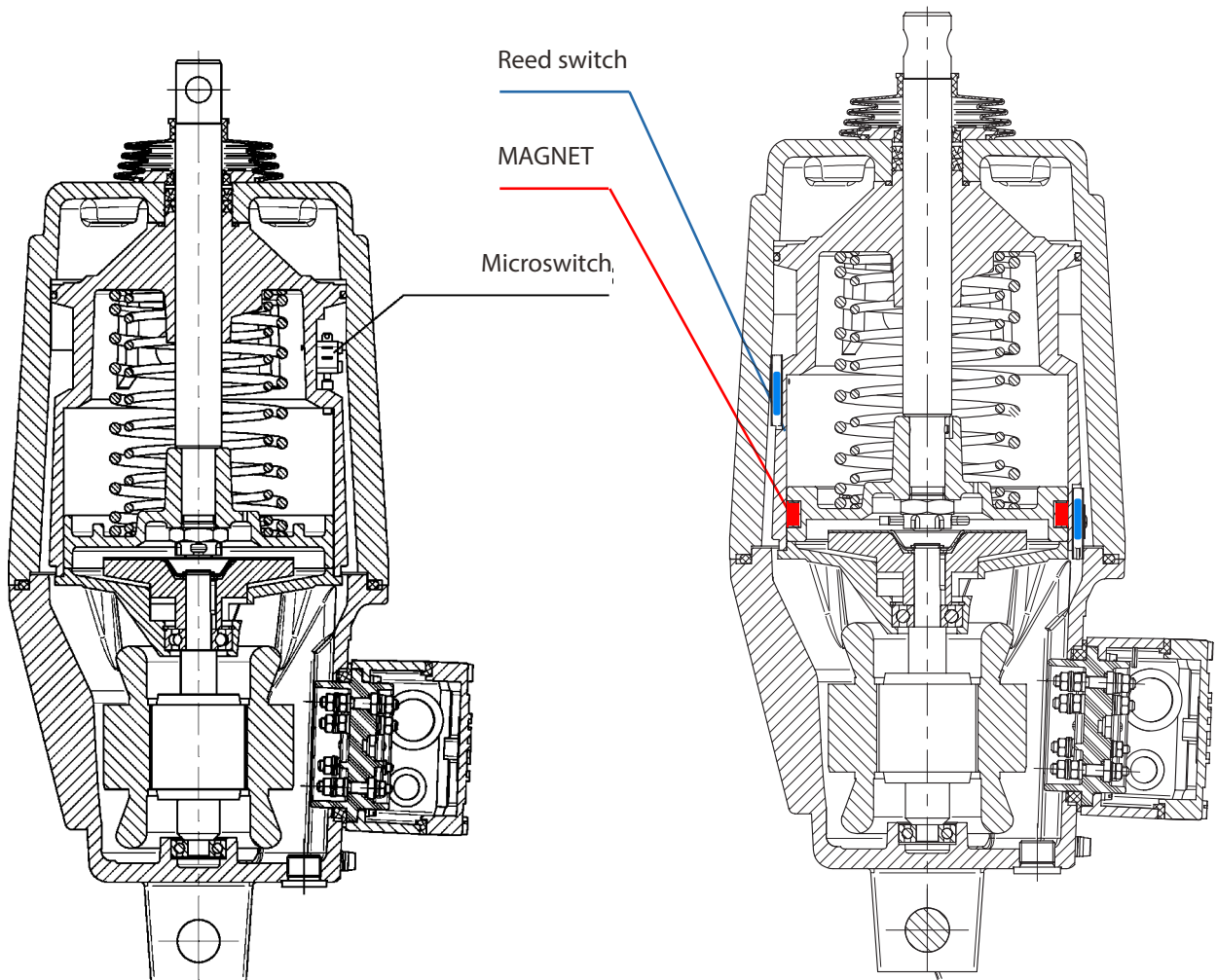

**Connecting box for device
variant "MP" and "Lk2"**

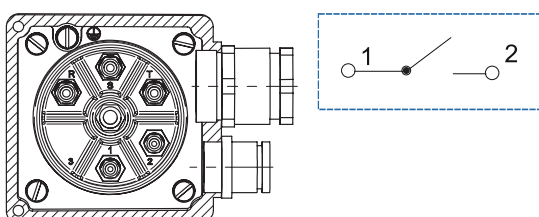

**Connecting box for
device variant "Lk4"**

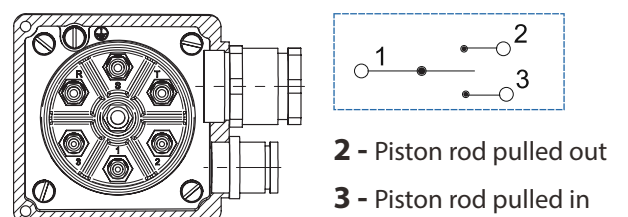

ELECTROHYDRAULIC THRUSTERS **F-REH** and **F-R**

TECHNICAL CHARACTERISTICS OF DEVICES

Size	Type	Nom. stroke	Nominal pushing force	Nominal return force	Power	Current	Mass	Lifting time	Lowering time
		mm	N	N	W	A	kg	s	s
1	F-R 12/5 F-R 12/5 c F-R 20/5 F-R 20/5 c	50	200	0 120 0 200	150	0,50	11.3	0,55	0,65
1.1	F-REH 12/50 N5H F-REH 12/50 N5C F-REH 20/50 N5H F-REH 20/50 N5C	50	200	0 200 0 200	150	0,50	11.3	0,55	0,65
2	F-R 32/5 F-R 32/5 c F-R 50/5 F-R 50/5 c	50	500	0 330 0 485	200	0,55	15.1	0,55	0,65
2.1	F-REH 32/50 N5H F-REH 32/50 N5C F-REH 50/50 N5H F-REH 50/50 N5C	50	500	0 330 0 485	200	0,55	15.1	0,55	0,65
3	F-R 80/6 F-R 80/6 c F-R 125/6 F-R 125/6 c	60	800 800 1250 1250	0 780 0 1180	350 350 400 400	0,60	24	0,55 0,55 0,65 0,65	0,60 0,60 0,60 0,60
3.1	F-REH 80/60 N5H F-REH 80/60 N5C	60	800	0 780	350	0,60	24	0,55	0,60
3.3	F-REH 80/120 N5H	120	800	0	350	0,6	28	0,90	0,80
3.2	F-REH 125/60 N5H F-REH 125/60 N5C	60	1250	0 1180	400	0,60	24	0,65	0,6
4	F-REH 200/60 N5H F-REH 200/60 N5C	60	2500	0 2000	500	0,80	40.5	0,70	0,6
5	F-REH 320/60 N5H F-REH 320/60 N5C	60	3200	0 2800	500	0,9	49	0,75	0,65
5.1	F-REH 320/120 N5H	120	3200	0	500	0,9	49	1,1	1.05

H without return spring

5 electric supply 3x400V 50Hz

C(c) without return spring

		Standard variant	For high temperatures		For low temperatures		
Symbol		N	T	TW06	TW07	L	
Environment temperature	maximum	+40°C	+45°C	+60°C	+70°C	+40°C	
	minimum	-25°C	-25°C	-10°C	-10°C	-45°C	
Hydraulic fluid - oil type		Insulation oil NYNAS NYTRO 4000X			AEROSHELL FLUID 41		
Voltage and motor frequency		3 x 400V 50Hz					
Duty of device		2.000 cycles/h or ED 100% (S1)	350 cycles/h or ED 35% (S3)	250 cycles/h or ED 25% (S3)	2.000 cycles/h or ED 100% (S1)		
Mechanical protection		IP 66					
Variant on customer request	Voltage of electromotor		od 200V do 660V				
	Frequency		od 42Hz do 60Hz				
	Work control	Mechanical switch	Im	External mechanical control sensor signals that the brake is raised (open)			Voltage 24...250V AC/DC; current 2,5A; external IP65: The guaranteed activation point is max. 0,3mm from the maximum position of the activated thruster
			Im1	External mechanical control sensor signals that the brake is raised (open) and brake lining are worn			
			MP	Internal mechanical control sensor signals that the brake is raised (open)			
	Inductive switch	In	External inductive control sensor signals that the brake is raised (open)			Voltage 15...250V AC 500 mA 45...65 Hz NO/NC	
		In1	External inductive control sensor signals that the brake is raised (open) and brake lining are worn				
	Magnetic-inductive switch	Lk2	Internal control sensor signals that the brake is raised (open)			Voltage 24...250V AC/DC; current 0,5A; The guaranteed activation point is max. 5mm from the maximum position of the activated thruster	
Lk4		Internal control sensor signals that the brake is raised (open) and brake lining are worn					

NOTES:

- Nominal pushing force for the device without a spring, is a declared force on the piston rod in the output direction. Maximum pushing force is ~ 50% higher. In devices with spring it is reduced by force springs.
- Nominal return force is a force of the spring for returning the piston rod and this information related to the 1/3 piston rod stroke. Tolerance is ±10%.
- The weight of the device and oil are approximate (depending on additional equipment).
- Time of lifting and lowering is related to a variant of the device without irreversible valve with built-in springs, i.e. with the corresponding external load. Tolerance is ±10%. In devices with built-in non return valve min. lifting and lowering time is greater for ~ 25%, while by the wring screw (13) can be continuously adjusted up to a maximum of 3- 5s for a stroke rate 50-60mm, 8-12s for the stroke rate 100 mm and 10-15s for the stroke rate 160mm.
- Nominal power and current refer to temperature of the device 20°C. Lowering temperature causes an increase in oil viscosity, in which case the nominal value of the power and current are growing and can be up to 50% higher.

POSITION OF TERMINAL BOX WHEN THE DEVICE WORKS IN A HORIZONTAL POSITION

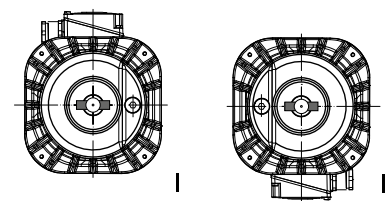

Foot bolt horizontal

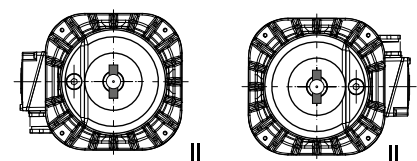

Foot bolt vertical

INSTALLATION DRAWING

VARIANT WITH SHOCK ABSORBER - R

VARIANT WITHOUT SHOCK ABSORBER - R

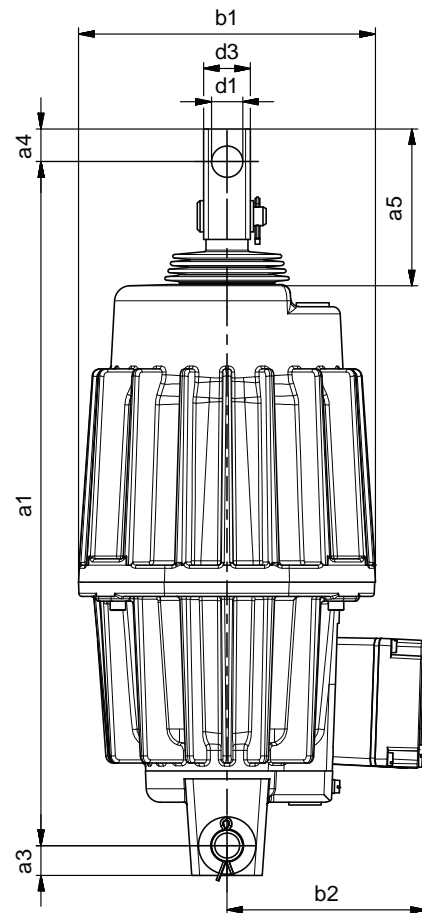
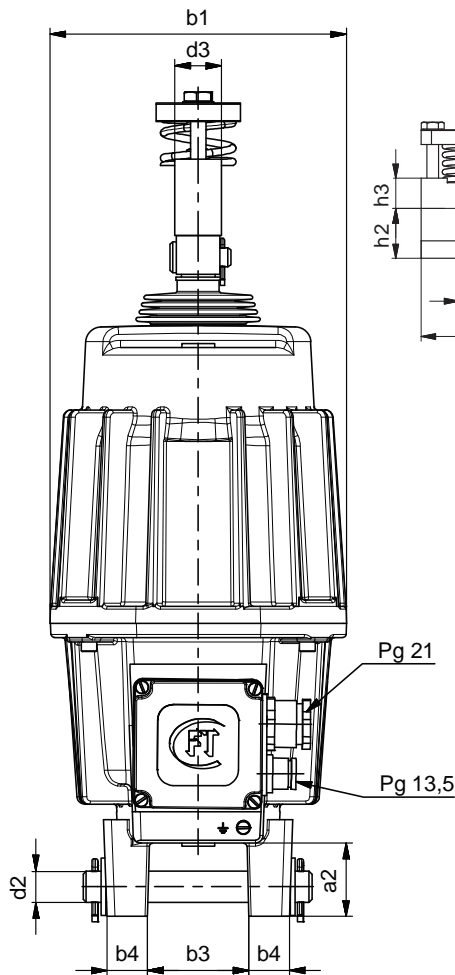

INSTALLATION DIMENSIONS:

DIMENSIONS	a1 ⁺¹	a2 ⁺¹	a3 ⁺¹	a4 ^{+0.2}	a5	b1 ⁺¹	b2 ⁺¹	b3 ⁺¹	b4 ⁺¹	b6	h1	h2	h3	h4	d1 ^{F9}	d2 ^{H11}	d3 ^{+0.2}
SIZE																	
1	416	50	20	18	94	152	125	87	24	68	15	40	20	120	20	18	40
1.1	370	40	20	18	48	152	125	32	20	68	15	40	20	120	16	16	45
2	428	50	20	16	88	182	130	110	30	68	20	34	25	110	20	25	40
2.1	450	50	20	16	110	182	130	40	25	68	20	34	25	110	20	25	50
3	515	55	25	25	114	210	140	116	38	110	20	38	35	175	20	25	40
3.1	450	50	25	20	49	210	140	40	25	110	20	38	35	175	20	25	50
3.2	620	55	25	20	218	210	140	40	25	110	20	38	35	175	20	25	60
3.3	530	50	25	20	63	210	140	40	25	110	20	38	35	175	20	25	60
4	620	55	25	25	135	255	150	40	25	110	11	29	35	112,5	20	25	60
5	675	55	25	25	80	255	150	40	25	110	11	29	35	112,5	20	25	60
5.1	800	55	25	25	205	255	150	40	25	110	11	29	35	112,5	20	25	60

ORDER INSTRUCTION

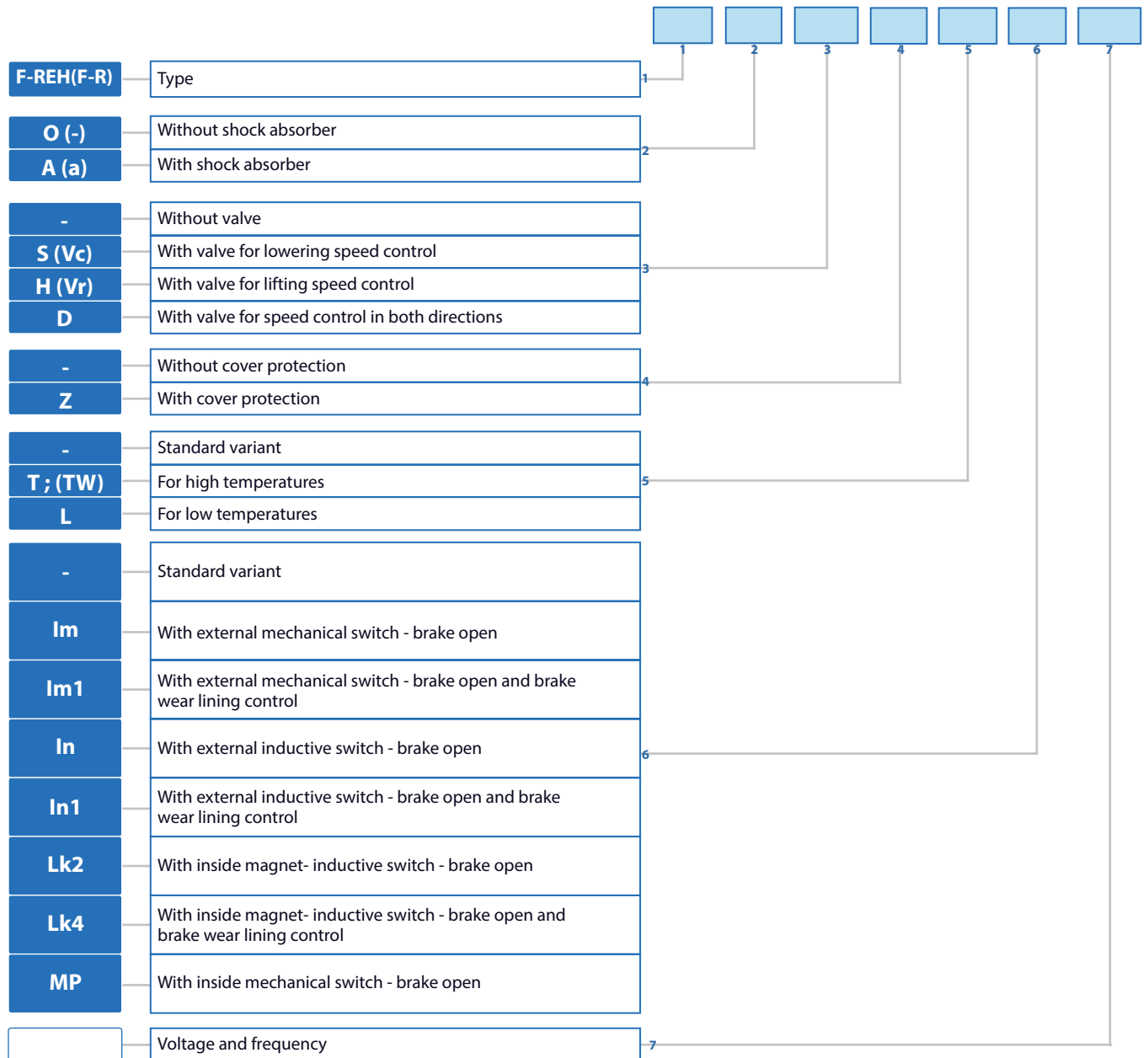



SERBIA
36210 VRNJACKA BANJA
Rudjinci 175/A
tel/fax: +381-36-631-710
E-mail: office@fluidotehnic.com
Web: www.fluidotehnic.com

Matični broj: 06568939
Šifra delatnosti: 2822
PIB: 100918689
Reg. broj: 11506568939
Br. Reg. Upisa: 1-14429-00



EC DECLARATION OF CONFORMITY / DECLARATION ON INSTALLATION

DEKLARACIJA O USAGLAŠENOSTI / DEKLARACIJA O UGRADNJI

We hereby declare that the following product

Izjavljujemo da su sledeći uređaji

ELECTROHYDRAULIC THRUSTER

ELEKTROHIDRAULIČNI PODIZAČI

ESM 12/50...ESM320/100 ; ESM 120-40...ESM 3200-100

F-EB 12/50...F-EB 320/100 ; F-EB 120-40...F-EB 3200-100

F-BL-12 ... F-BL-320

F-EHT-12.5-50 ... F-EHT-250-60 ; F-EHT-338 ... F-EHT-2960

F-SZH 45/50 ... F-SZH 185/120

F-TGM 25 ... F-TGM 50

F-R 12/5 ... F-REH 320/120 N5H

F-Ed 12/4.1 ... F-Ed 301/12.1

Are designed and produced in accordance with the safety requirements according to the following regulations:

Projektovani i proizvedeni u skladu sa bezbednosnim zahtevima prema sledećim propisima:

Machinery Directive EC/2006/42

(Mašinska direktiva EC/2006/42)

Low voltage directive EC/2014/35

(Niskonaponska direktiva EC/2014/35)

in accordance with the following standards:

i u skladu sa sledećim standardima:

Safety of machinery - General principles for design

- **Risk assessment and risk reduction EN ISO 12100:2010**

Bezbednost mašina - Opšti principi za projektovanje

- Ocena rizika i smanjenje rizika SRPS ISO 12100:2014

Safety of machinery - Electrical equipment of machines - Part 1: EN 60204-1:2016

Bezbednost mašina - Električna oprema mašina - Deo 1: EN 60204-1:2016

Declaration on installation in the sense of EC Machinery Directive (2006/42/EC) Annex II B

Izjava o ugradnji u skladu sa EC Mašinskom direktivom (2006/42/EC) Anex II B

Electrohydraulic thrusters of "FLUIDOTEHNIC" assemble into mechanical devices and equipment. Start-up is not admissible unless it has been verified that the whole equipment, meets the requirements defined in the EC machinery Directive (2006/42/EC)

Elektrohidraulični podizači "FLUIDOTEHNIC"-a se ugrađuju u drugu opremu i dodatne uređaje. Pokretanje nije dozvoljeno sve dok i relevantna oprema u koju se ugrađuju ne bude u skladu sa Mašinskom direktivom (2006/42/EC)

The manufacturer undertakes to supply the relevant information of incomplete machine on request to responsible inspector by electronic way. Technical documents of the machine is prepared in accordance with Annex VII, part B Machinery Directive (2006/42/EC)

Proizvođač se obavezuje da će elektronskim putem dostaviti odgovarajuće podatke o delimično završenoj mašini nadležnom inspektor na njegov zahtev. Tehnička dokumentacija je izrađena u skladu sa Anexom 7, deo B Mašinske direktive.

Vrnjačka Banja, 01/02/2017 godine



Šljivić Miroslav, General Manager

The EC Declaration of Conformity is only valid in conjunction with confirmation that the device has been correctly applied, installed, inspected and maintained according to the operating instructions provided. The validity of the declaration will cease in case of any modification and/or supplement not previously approved by "FLUIDOTEHNIC".

Ova deklaracija o usaglašenosti važi samo u slučaju da je uređaj pravilno ugrađen, iskontrolisan i da se koristi i održava u skladu sa uputstvom za rukovanje i održavanje. Važenje izjave prestaje u slučaju bilo kakve modifikacije ili dodatka koji nisu prethodno odobreni od "FLUIDOTEHNIC"-a.



- FLUIDOTEHNIC's production program is based on its own development. Thanks to that, all the products are the result of the engineering staff work, as well as the quality and skilled workers in manufacturing and installation. Each serial product during the conquest passes through the phase of prototype development, functional tests and check in real operating conditions. Following step is removal of all possible defects and then, based on that, test series is produced. This is how we achieve high quality of manufactured devices. In case of the individual production, after the functional testing, we deliver the product to the customer.
- Since its foundation FLUIDOTEHNIC Ltd. has been continuously investing both in the expansion of commercial building and the purchase of modern equipment for the production, control and techno-economic support. It is located in the industrial zone of Vrnjacka Banja, on a lot size ~ 2ha. It consists several buildings, connected into a functional whole area of 4000 m2. The whole complex is adjusted to the environment- we are taking good care of health, work safety and environmental protection.





- Market research, device development, technical assistance and personnel training free of charge for all our customers is the main task of this service. Many years of experience in the development tasks of hydraulics, pneumatics and lubrication techniques, as well as the latest computer technology guarantee that our customers will get the optimum technical solution. During the development, every device passes precisely defined procedure, starting from making the design concept, followed by manufacturing and testing prototypes and going into production.
- It consists of several facilities and departments: foundry of non-ferrous metals, mechanical drive, locksmith department, installation and technical control. All operations from the casting to the final machining are performed with the universal and software machines. Control and assembly is 100%. When the assembly is finished, each device is being tested on the test stand and on the basis of the results it gets the appropriate certificates and guarantees. On each call of the user, service teams come in as soon as possible, with spare parts and the necessary tools, regardless of whether the equipment is in warranty or out of warranty period.





Fluidotehnic d.o.o.

Serbia

36210 Vrnjacka Banja

Rudjinci 175/A

Tel: +381-(0)36-631-710

+381-(0)36-631-711

Fax: +381-(0)36-631-712

www.fluidotehnic.com

office@fluidotehnic.com

© Fluidotehnic doo

02/2018